



ANDHRA ELECTRONICS LIMITED

BAND PASS FILTER

PART NO: AE.BPF.1225

FREQ: 122.5 MHz

1. Center Frequency(Fc)	:	122.5 MHz
2. Insertion Loss	:	3dB(max)
3. Pass Band	:	$F_c \pm 7.5$ MHz
4. Rejection @ 50 dB	:	$F_c \pm 56$ MHz
5. Ripple In Pass Band	:	0.5dBMax
6. Input Return Loss	:	20dB
7. Output Return Loss	:	20dB
8. Impedance	:	50 Ω
9. Spurious	:	60dBMin
10. VSWR(IN&OUT)	:	1.2:1
11. Operating Temperature	:	-40 to +85degC
12. Package	:	Pin Version
13. Dimensions	:	25.40x12.70x10.20

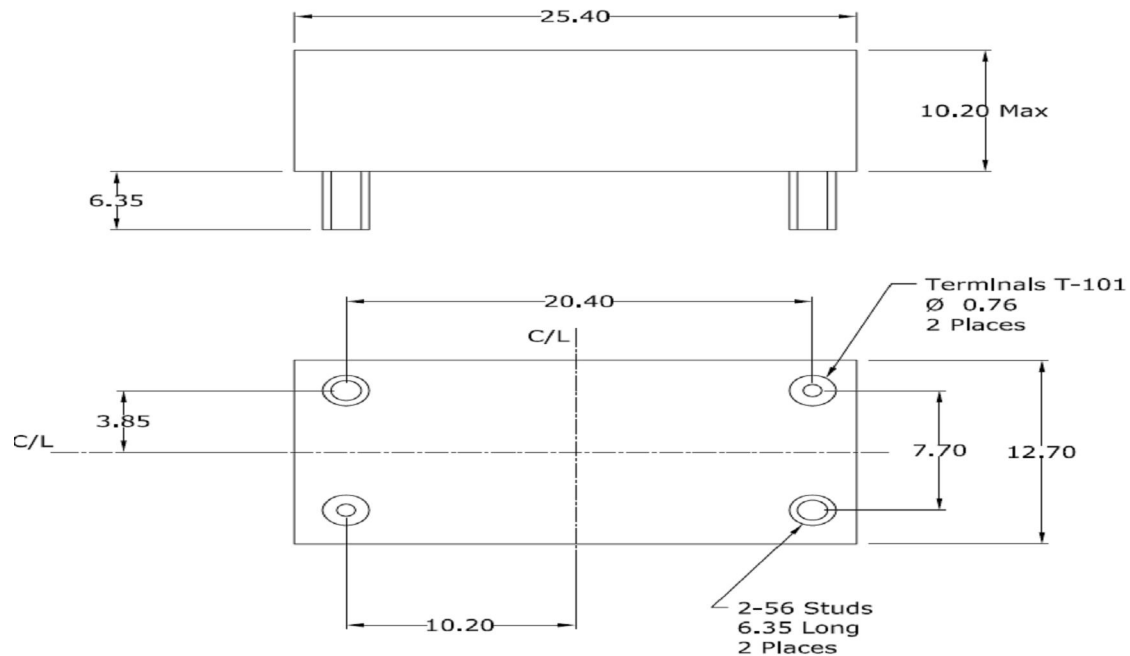

Plot Nos.34 & 35, Industrial Development Area, KAKINADA - 533 005, INDIA.

Phone: 91-884-2342203 / 2341850 / 2379407 ♣ Fax: 91-884-2341145 / 2379408

E-mail: info@andhraelec.com ♣ www.andhraelec.com

ISO 9001

BUREAU VERITAS
Certification





ANDHRA ELECTRONICS LIMITED

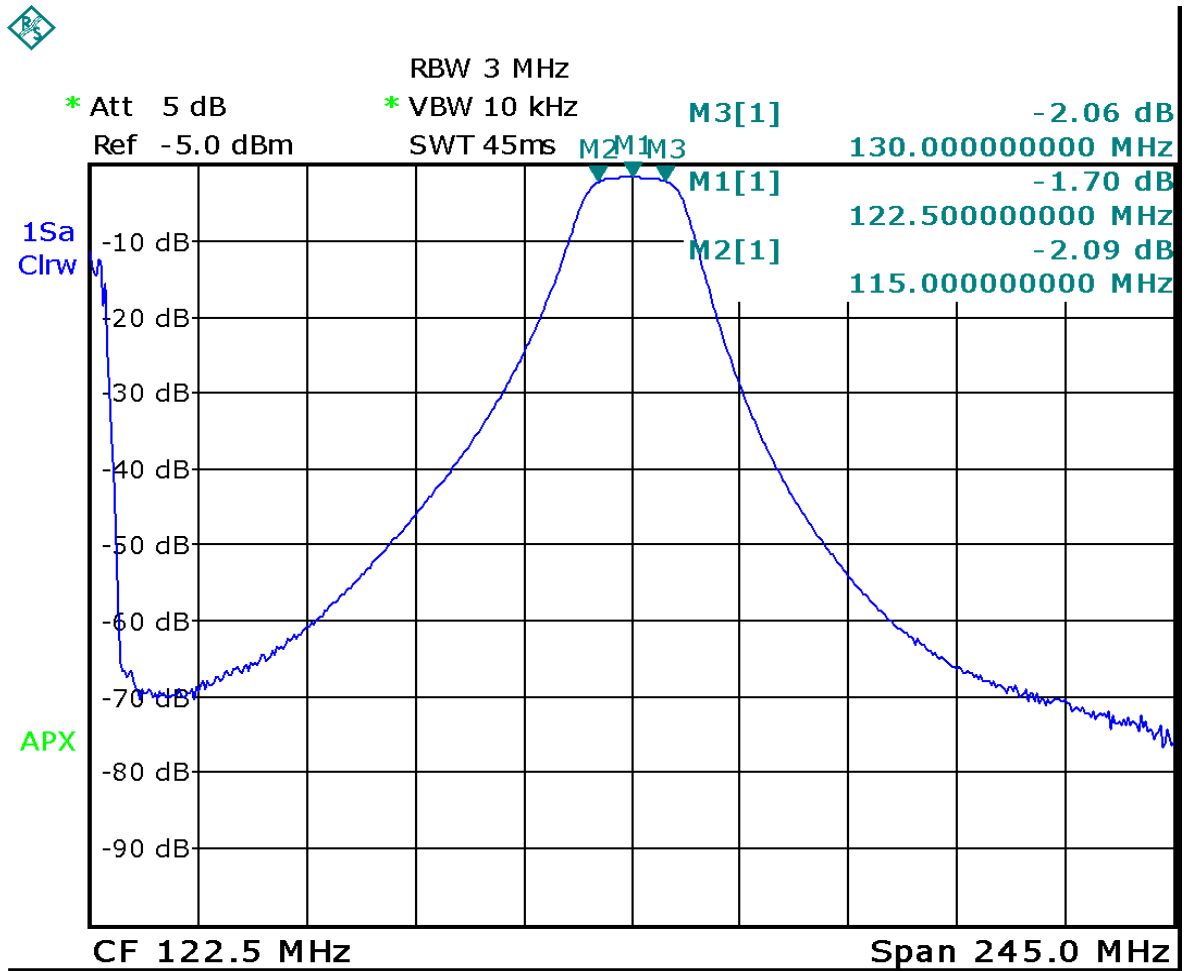

Date: 31.AUG.2010 12:24:17

Plot Nos.34 & 35, Industrial Development Area, KAKINADA - 533 005, INDIA.
Phone: 91-884-2342203 / 2341850 / 2379407 ♣ Fax: 91-884-2341145 / 2379408
E-mail: info@andhraelec.com ♣ www.andhraelec.com

