



ANDHRA ELECTRONICS LIMITED

BAND PASS FILTER

PART NO: AE.BPF.3720

FREQ: 372 MHz

1. Center Frequency(Fc)	:	372 MHz
2. Insertion Loss	:	3dB(max)
3. Pass Band@3dB	:	$F_c \pm 5$ MHz
4. Ripple In Pass Band	:	0.5dBMax
5. Rejection @ 50 dB	:	$F_c \pm 60$ MHz
6. Impedance	:	50 Ω
7. Spurious	:	60dBMin
8. VSWR(IN&OUT)	:	1.4:1
9. Operating Temperature	:	-40 to +85degC
10. Package	:	Pin Version
11. Dimensions	:	25.40x12.70x10.20

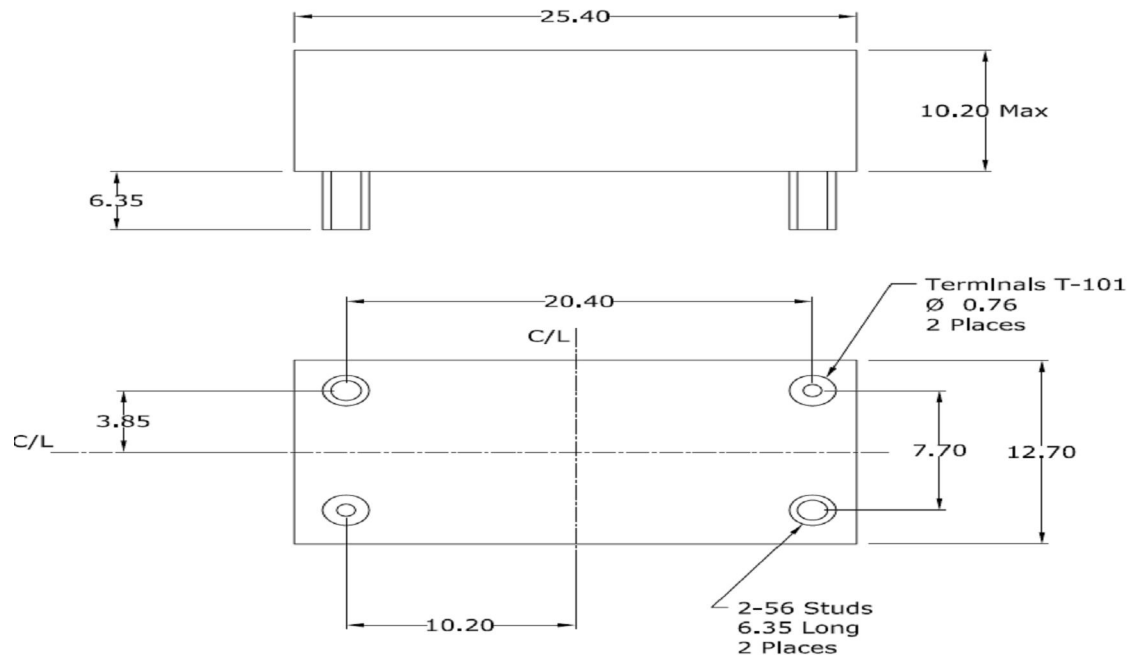

All Dimensions are in mm

Plot Nos.34 & 35, Industrial Development Area, KAKINADA - 533 005, INDIA.

Phone: 91-884-2342203 / 2341850 / 2379407 ♣ Fax: 91-884-2341145 / 2379408

E-mail: info@andhraelec.com ♣ www.andhraelec.com





ANDHRA ELECTRONICS LIMITED

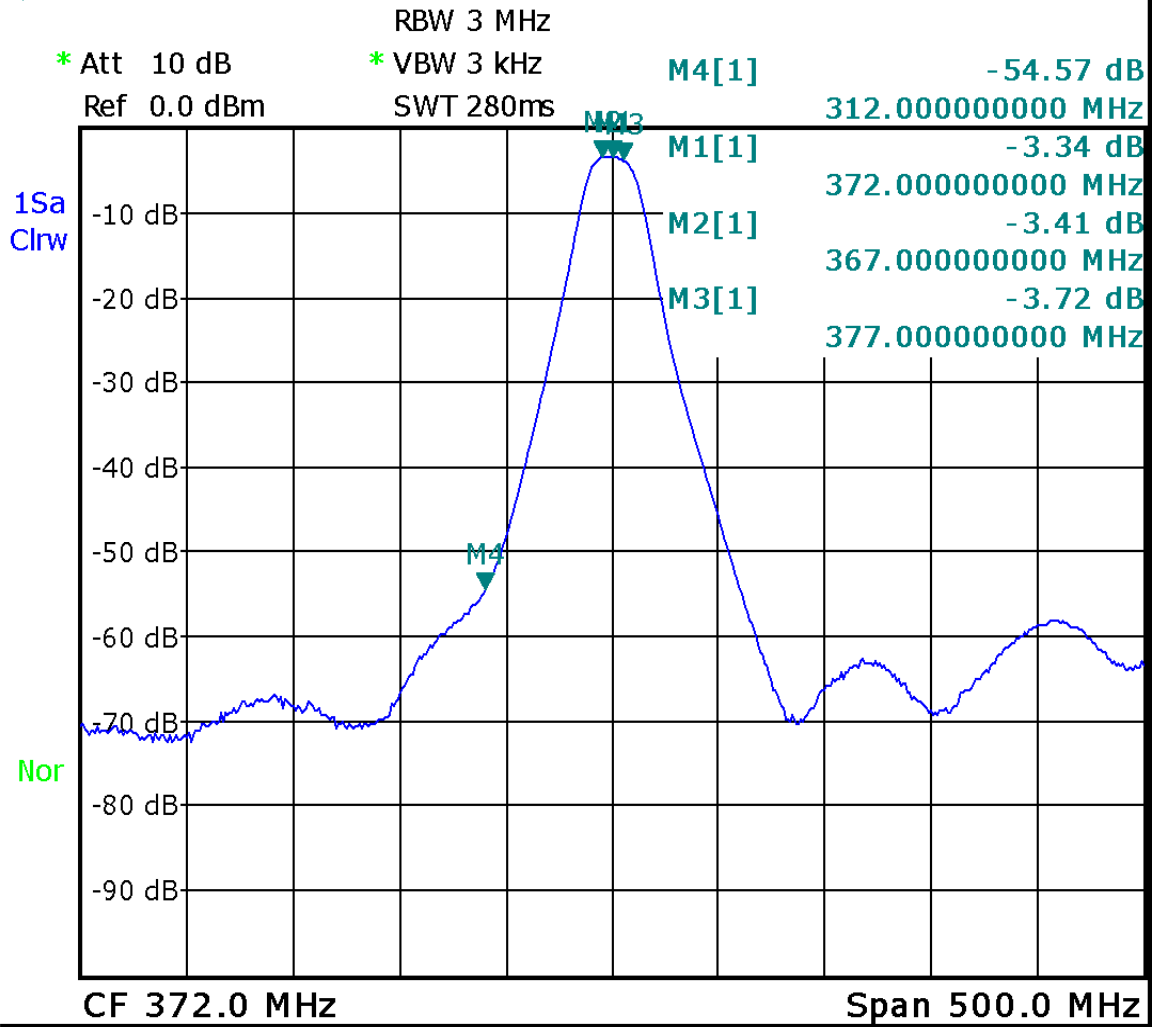

Date: 27.JUL.2010 17:18:17

Plot Nos.34 & 35, Industrial Development Area, KAKINADA - 533 005, INDIA.
 Phone: 91-884-2342203 / 2341850 / 2379407 ♣ Fax: 91-884-2341145 / 2379408
 E-mail: info@andhraelec.com ♣ www.andhraelec.com

